







270° AND 360° REVOLVING MAGIC CORNER COIN MAGIQUE PIVOTANT 270° ET 360°

Use these instructions for the following items / Suivez ces instructions pour les items suivants

23-722-4 23-722-5
102001 103001

Description	Picture Image	Qty Qté
Top Fixture / Fixture du haut		1
Bottom Fixture / Fixture du bas		1
Gasket / Joint		2
Nut / Écrou		1
ST3. 5 x 25 Tapping Screw ST3. 5 x 25 vis taraudeuses		4
ST3. 5 x 16 Tapping Screw ST3. 5 x 16 vis taraudeuses		5

Step 1: As shown in the picture below, drill 9 small 3.0mm holes respectively on the top and bottom panels.
Étape 1 : Tel que démontré ci-dessous, faire 9 petits trous de 3.0 mm respectivement sur les panneaux du haut et du bas.

T=Cabinet / Caisson	Sizes / Dimensions
900 mm	ø800 x (650-750)
900 mm	ø800 x (650-750)

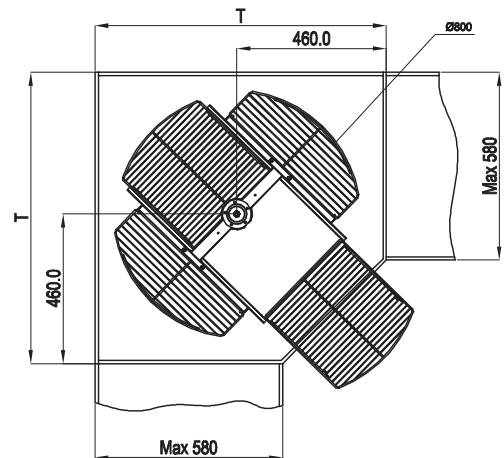
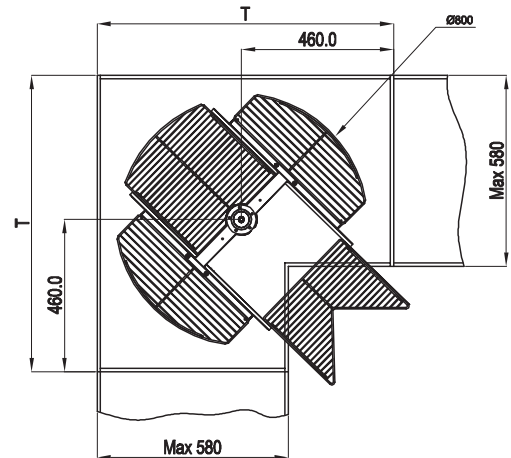

Cabinet top panel
Panneau supérieur du caisson

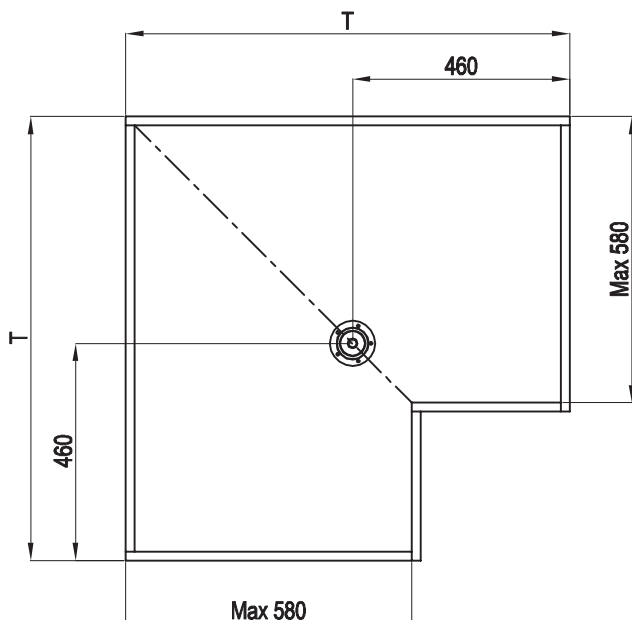

Cabinet bottom panel
Panneau inférieur du caisson

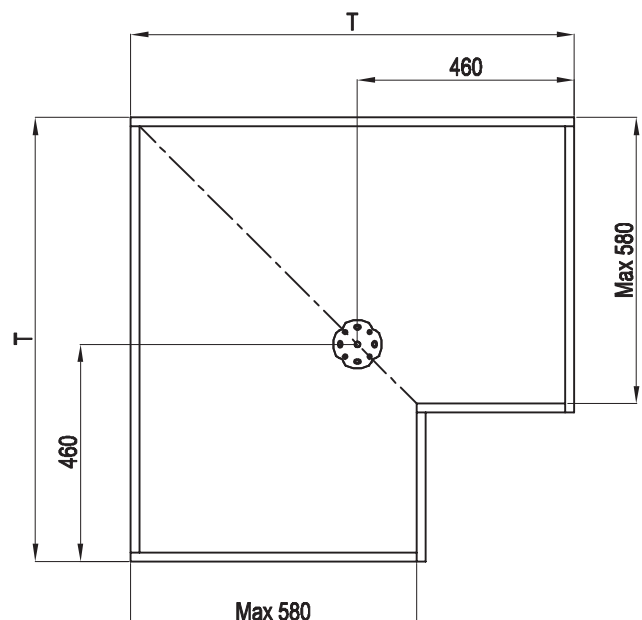

Step 2: Use 4 screws to connect the side panels with the central bar.
Étape 2: À l'aide d'une barre de renfort, assemblez les deux côtés avec 4 vis.

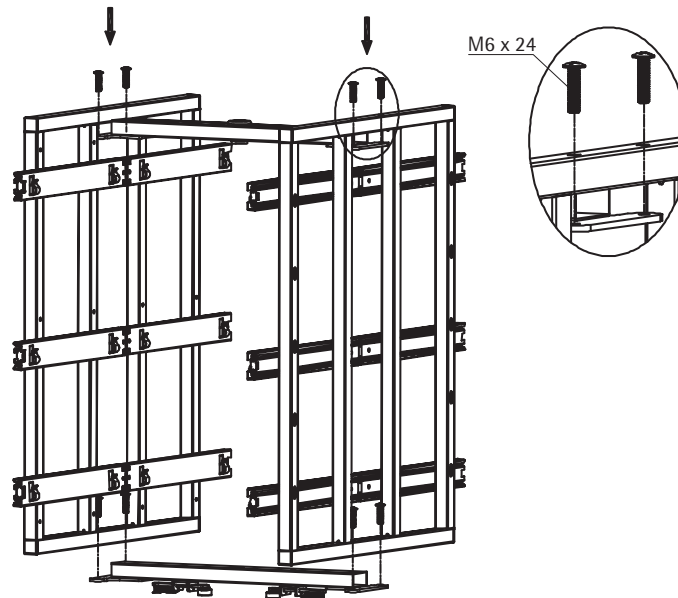

Step 3: Install the top and bottom fixtures into the holes of the central bar and fasten with screws.
Étape 3: Installez les fixtures du haut et du bas dans les trous de la barre de renfort et vissez-les.

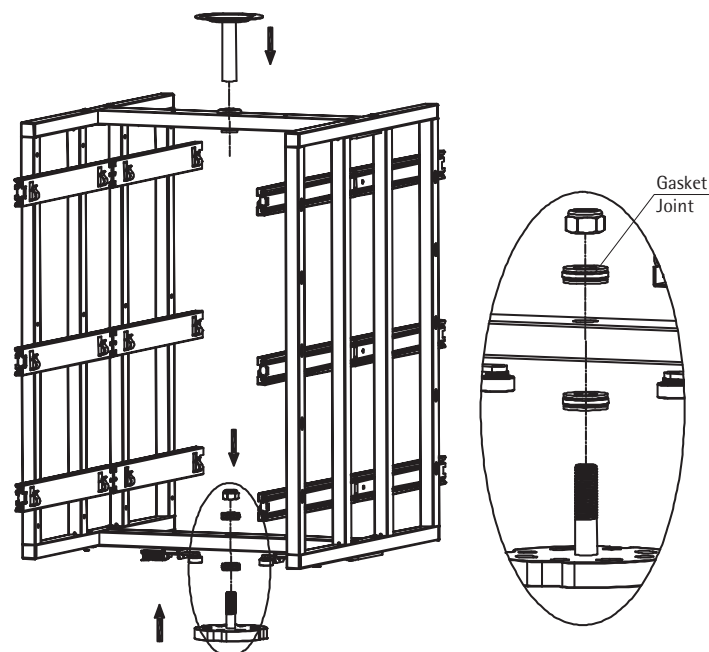

Step 4: Install the frame into the cabinet, and use the self-tapping screws to fix the upper and lower fixtures to the cabinet's top and bottom panels.

Étape 4 : Installez le cadre dans le caisson et utilisez les vis taraudeuses pour installer les fixtures du haut et du bas.

