









Use these instructions for the following items / Suivez ces instructions pour les items suivants

23-740-0 23-741-0 23-742-0 23-743-0
201002 201005 201008 201014

Description	Picture Image	Qty Qté
T-Shaped Bracket Support en T		2
Bridge Shaped Bracket Support		1pc for 2, 3, 4 tiers 2 pcs for 5 tiers 3 pcs for 6 tiers 1pc pour 2, 3, 4 étages 2 pcs pour 5 étages 3 pcs pour 6 étages
U-Shaped Bracket Support en U		Basket qty x 4 Qté de panier x 4
M8X30 Screw Vis M8X30		4

Description	Picture Image	Qty Qté
Gasket Joint d'étanchéité		4
ST3.5 x 16 Tapping Screw ST3.5 x 16 vis taraudeuse		22/26/30
ST3.5 x 20 tapping screw ST3.5 x 20 vis taraudeuse		8
Upper Slide Coulisse du haut		1
Lower Slide Coulisse du bas		1

Step 1: As shown in the picture below, drill 8 pcs small holes of 2.5mm each on the cabinet top panel.

Étape 1: Tel que démontré dans l'image ci-dessous, percez 8 petits trous de 2.5 mm sur le panneau dans le haut du caisson.

Step 2: As shown in the picture below, drill 10 pcs small holes of 2.5mm each on the cabinet bottom panel.

Étape 2: Tel que démontré dans l'image ci-dessous, percez 10 petits trous de 2.5 mm sur le panneau dans le bas du caisson.

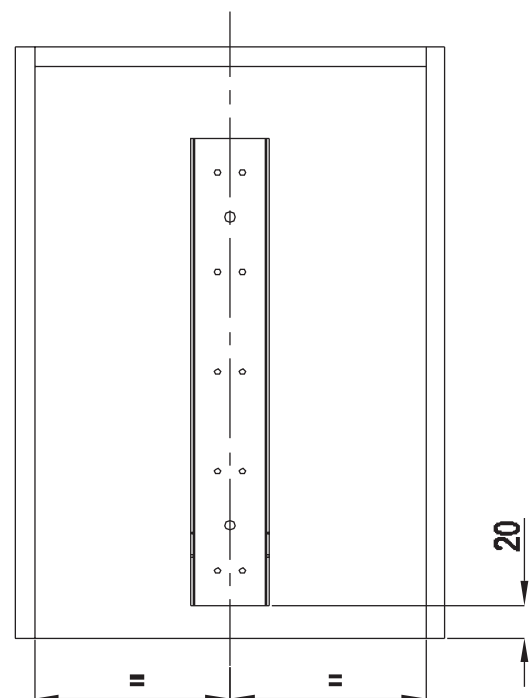
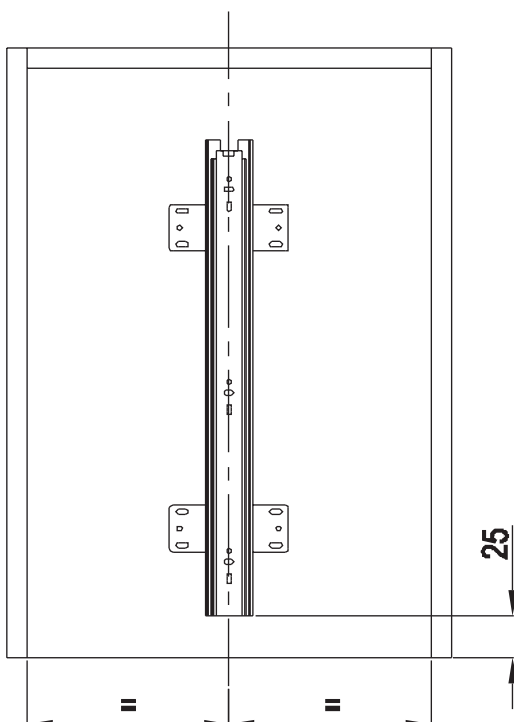

Step 3: Adjust frame height.
Étape 3: Ajustez la hauteur du cadre.

Inside cabinet height B-87 = Outside frame height A
 B= mm -87 = A = mm
 Hauteur intérieure caisson B-87 = Hauteur cadre extérieur A
 B= mm -87 = A = mm

Step 4: Attach top cabinet rail.
 Attach bottom cabinet rail.
Étape 4: Assemblez le rail du haut du caisson.
 Assemblez le rail du bas du caisson.

Step 5: Install the frame onto the bottom runner and fix it into the bottom runner with four screws M8 x 25.
Étape 5: Vissez le cadre à la coulisse du bas à l'aide de 4 vis M8 x 25.

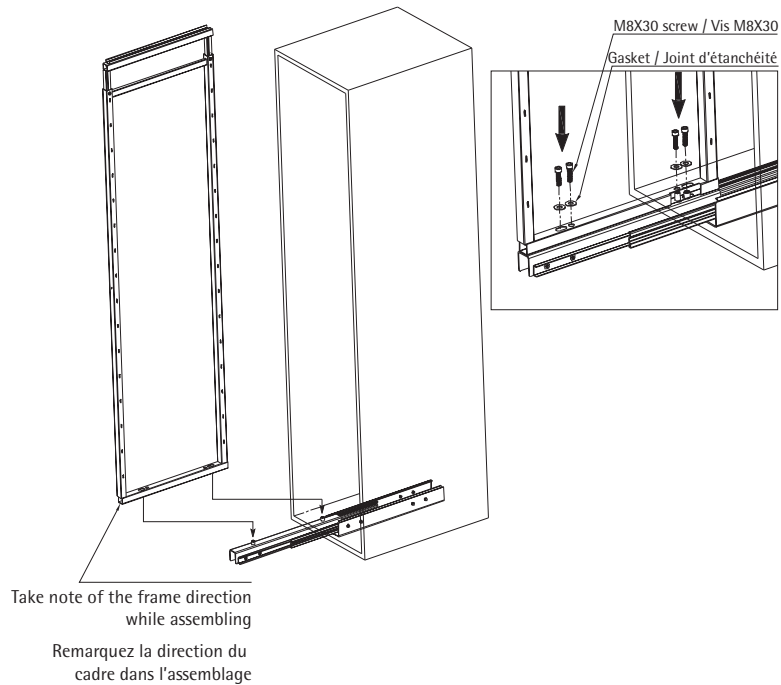
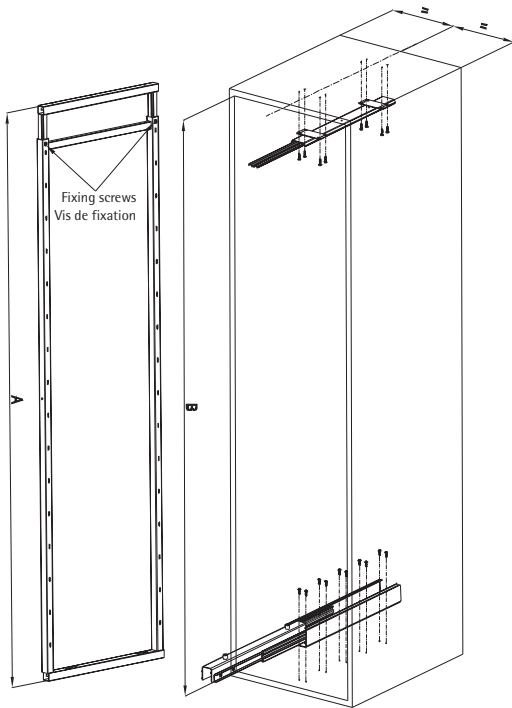

Step 6: Attach frame to top cabinet rail.
Étape 6: Fixez le cadre au rail dans le haut du caisson.

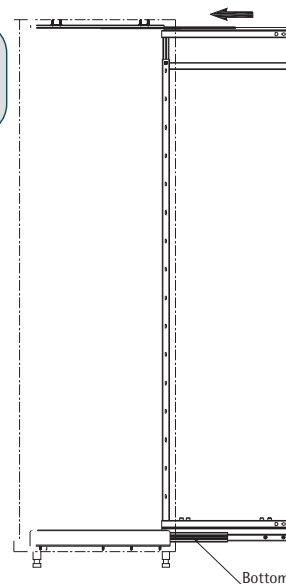
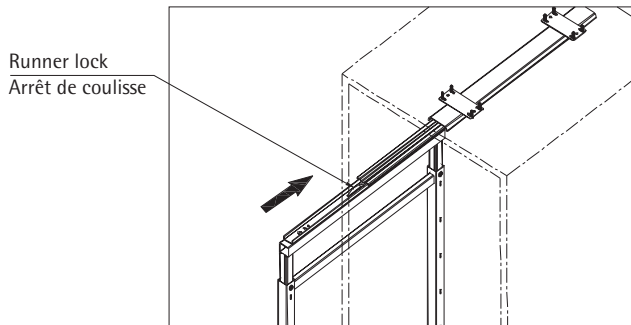

A. Pull out the bottom runner and frame completely to make sure that the top of the frame extends past the top runner.

B. Install the inner rail of the frame top runner into the top runner.

NOTE: make sure that the runner lock is in the middle rail of the top runner.

A. Retirez le cadre et la coulisse du bas complètement pour s'assurer que le haut du cadre dépasse la coulisse du haut.

B. Installez le rail intérieur dans la coulisse du haut du cadre.

À noter : Assurez-vous que l'arrêt de coulisse est dans le rail du centre de la coulisse.

Step 7: Attach front panel connectors.
Étape 7 : Fixez les connecteurs du panneau avant.

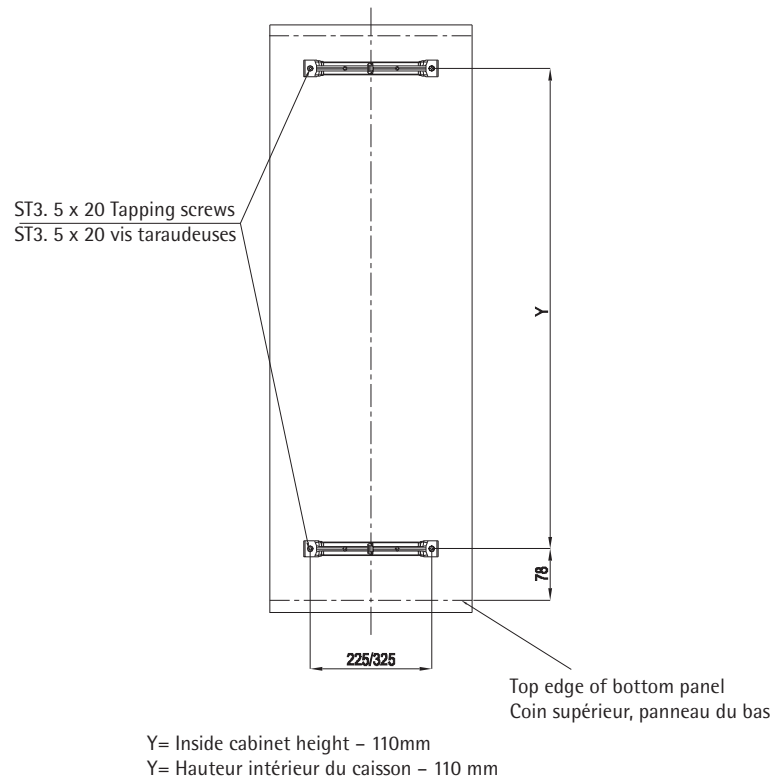

Step 8: Install the door.
Étape 8 : Installez la porte.

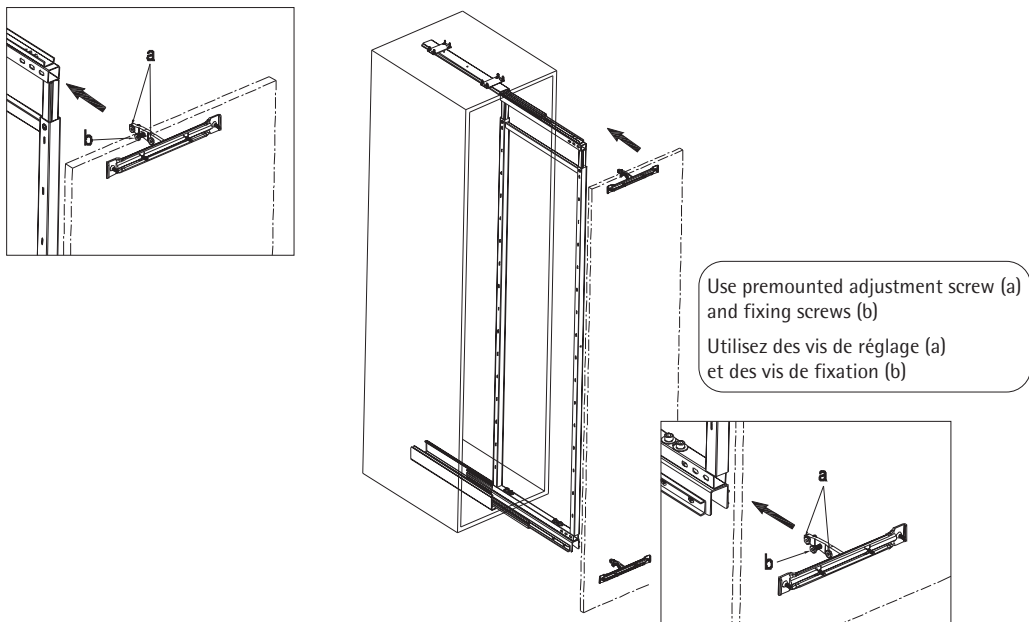

Step 9: Connect the frame and door panel through the bridge shaped bracket.
Étape 9 : Assemblez le cadre et le panneau de la porte au support.

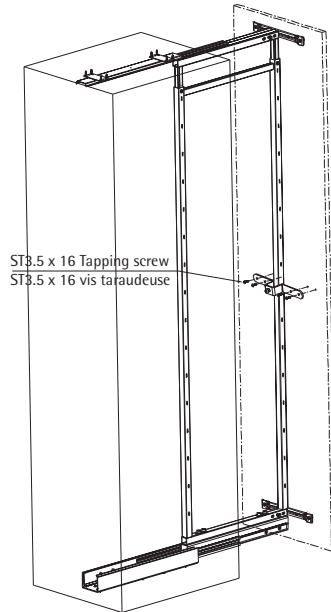

	Qty / Qté
2, 3, 4 baskets / 2, 3, 4 paniers	1 pcs / 1 m.
5 baskets / 5 paniers	2 pcs / 2 mx
6 baskets / 6 paniers	3 pcs / 3 mx

Step 10: Align front panel.
Étape 10 : Alignez le panneau avant.

Step 11: Adjust front panel height and tilt.
Étape 11 : Ajustez la hauteur du panneau avant et inclinez.

 Loosen fixing screws
 before making any
 adjustments
 Desserrez les vis de
 fixation avant
 d'ajuster

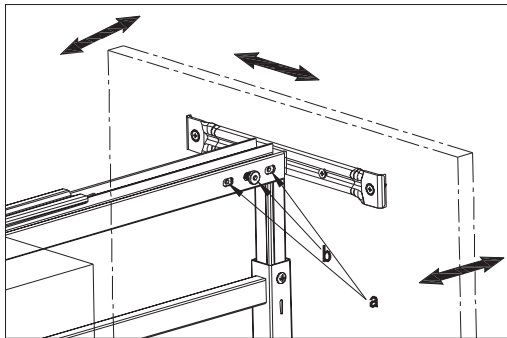

a - Adjusting
 a - Ajustez

b - Fixing
 b - Fixez

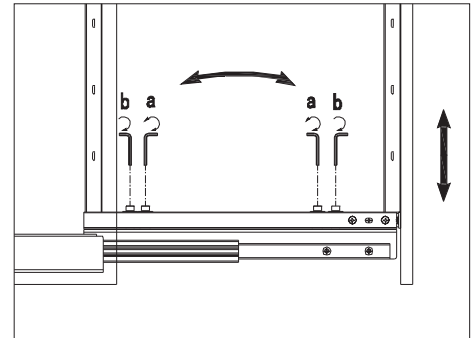

CAUTION:

Front panel tilt, the top of the front panel must close against the cabinet before the bottom.

À NOTER :

Pour l'inclinaison du panneau avant, le haut du panneau doit fermer contre le caisson avant le bas.