







270° REVOLVE BASKET PANIER PIVOTANT 270°

Use these instructions for the following item / Suivez ces instructions pour l'item suivant

23-730-4
10112

Cabinets / Caissons	Sizes / Dimensions
800 mm	ø710 X H (600-730)
900 mm	ø810 X H (600-730)

Description	Picture / Image	Qty / Qté
Post Poteau		1
Handle support Poignée de support		2
Lock washer Rondelle d'arrêt		2
Bottom mounting bracket Support de fixation du bas		1
Top mounting bracket Support de fixation du haut		1
Peg Cheville		2
St3. 5 X 16 Tapping screw St3. 5 X 16 Vis taraudeuse		10

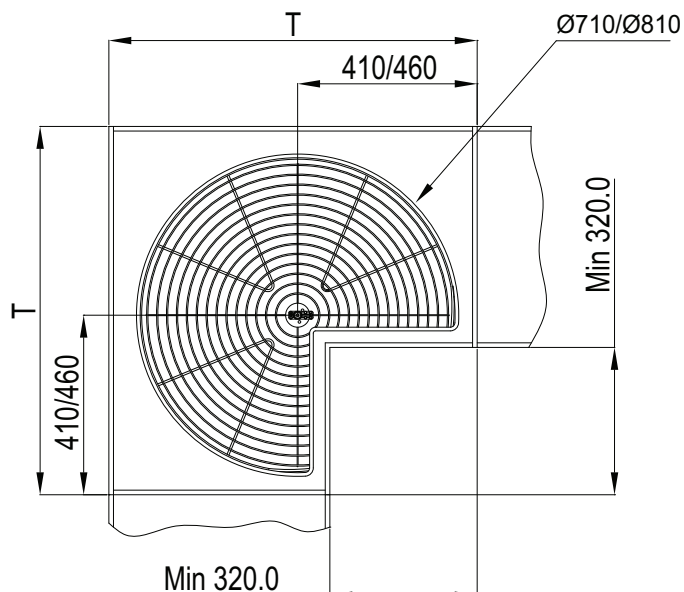

Step 1: As shown, drill 5x10mm holes in the left bottom cabinet, make a mark at the top to the cabinet and install the bottom mounting bracket and the top mounting bracket.

Étape 1 : Tel que démontré, percez des trous de 5x10mm en bas côté gauche du caisson, faire la marque en haut du caisson. Installez les supports de fixation du bas et du haut du caisson.

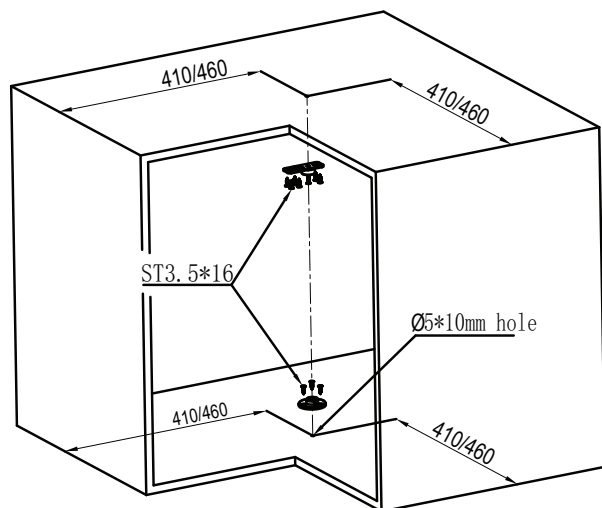

Step 2: Mount the center post and trays/baskets.

Étape 2 : Montez le poteau central et les plateaux/paniers.

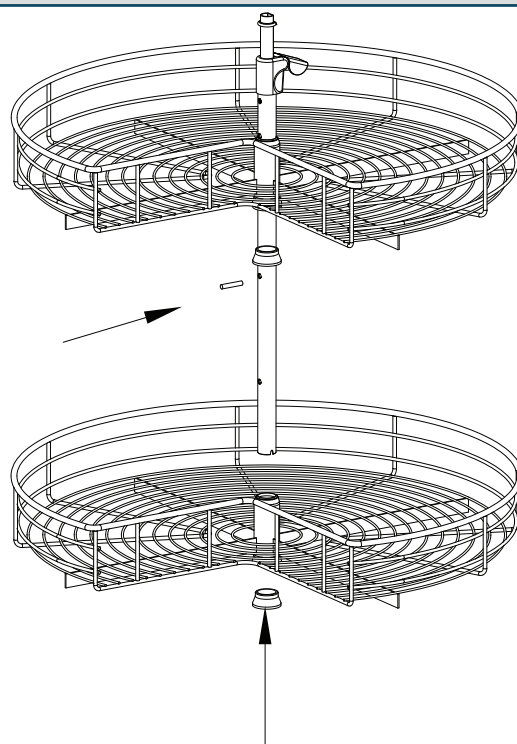

Step 3: Install the lock washer.
Étape 3 : Installez la rondelle d'arrêt.

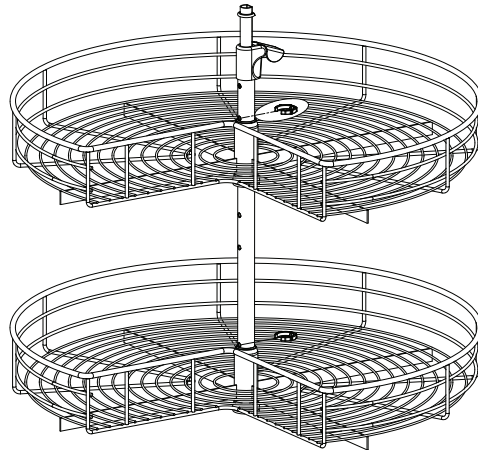
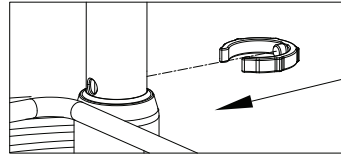

Step 4: Install the unit into the cabinet.
Étape 4 : Installez le montage à l'intérieur du caisson.

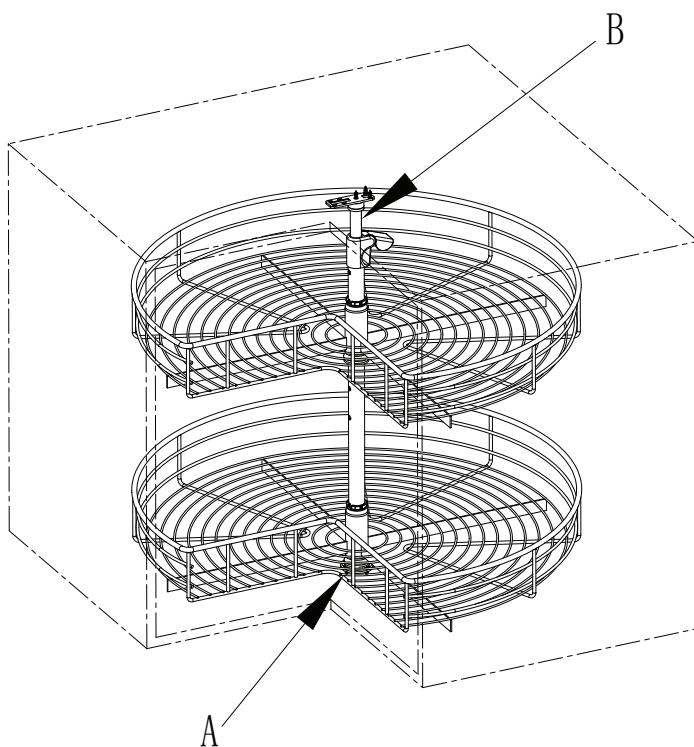

Picture A
Dessin A

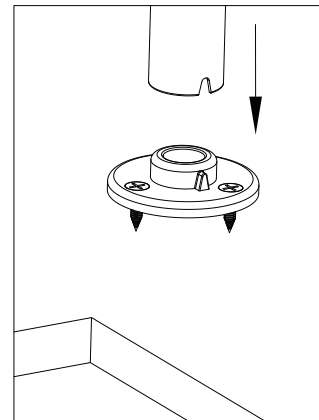

Picture B
Dessin B

